

FEATURES

- Sealed for Environmental Protection
- Water Immersion to 300 ft(91m).
- Integral Cable
- External Male Threads
- 5point Tension & Compression Calibration
- Proprietary Modulus Compensated Strain Gages
- Optional Female Thread
- Metric Capacities Available- Consult Factory



SPECIFICATIONS

Model	DSLC	DSLC-S1
Capacity U.S. lbf.	500, 1000, 5K	2.5K, 5K, 7.5K
PARAMETERS		
ACCURACY		
Static Error Band, % Rated Output	+/-0.250	+/-0.250
Nonlinearity, % Rated Output	+/-0.250	+/-0.250
Hysteresis, % Rated Output	+/-0.150	+/-0.150
Nonrepeatability, % Rated Output	+/-0.050	+/-0.050
Creep, % in 20 minutes	+/-0.030	+/-0.030
Zero Balance, % Rated Output	+/-1.0	+/-1.0
TEMPERATURE		
Range, Compensated, °F	+15 to +115	+15 to +115
Range, Compensated, °C	-10 to +45	-10 to +45
Range, Operating, °F	-65 to +200	-65 to +200
Range, Operating, °C	-55 to +90	-55 to +90
Effect on Sensitivity, % Rdg/ °F	+/-0.0015	+/-0.0015
Effect on Sensitivity, % Rdg/ °C	+/-0.0027	+/-0.0027
Effect on Zero, % Rated Output/ °F	+/-0.0015	+/-0.0015
Effect on Zero, % Rated Output/ °C	+/-0.0027	+/-0.0027
ELECTRICAL		
Rated Output, mV/V, Nominal	1	1
Excitation Voltage, VDC Maximum	15	15
Input Resistance, Ohms	1000 +100/-10	1000 +100/-10
Output Resistance, Ohms	1000 +100/-10	1000 +100/-10
Insulation Resistance, Megohm	5000 (@ 50VDC)	
MECHANICAL		
Safe Overload Range, % Rated Capacity	+/-150	+/-150
Weight lb	0.7	0.8
Flexure Material	Stainless Steel	Stainless Steel

DIMENSIONS

Capacity	DSLC 500, 1000, 5K lbf	DSLC-S1 2.5K, 5K, 7.5K lbf
Dimensions	inch	inch
1.	3.50	3.50
2.	1.70	1.70
3.	R 1.57	R 1.57
4.	5/8-18	3/4-16
5.	.75	.75

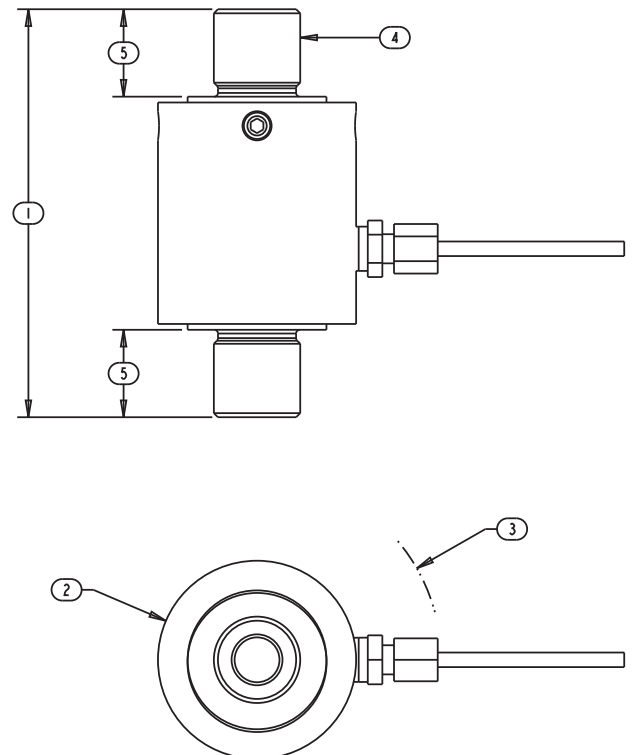

Load Cell Central follows a policy of continuous improvement and reserves the right to change specifications without notice. © 2016