

# Temposonics®

Magnetostrictive Linear Position Sensors

## GB-M / GB-T Analog Data Sheet

- Sensor element and electronics can be changed
- Flat & compact sensor electronics housing
- Electrical connection is freely rotatable

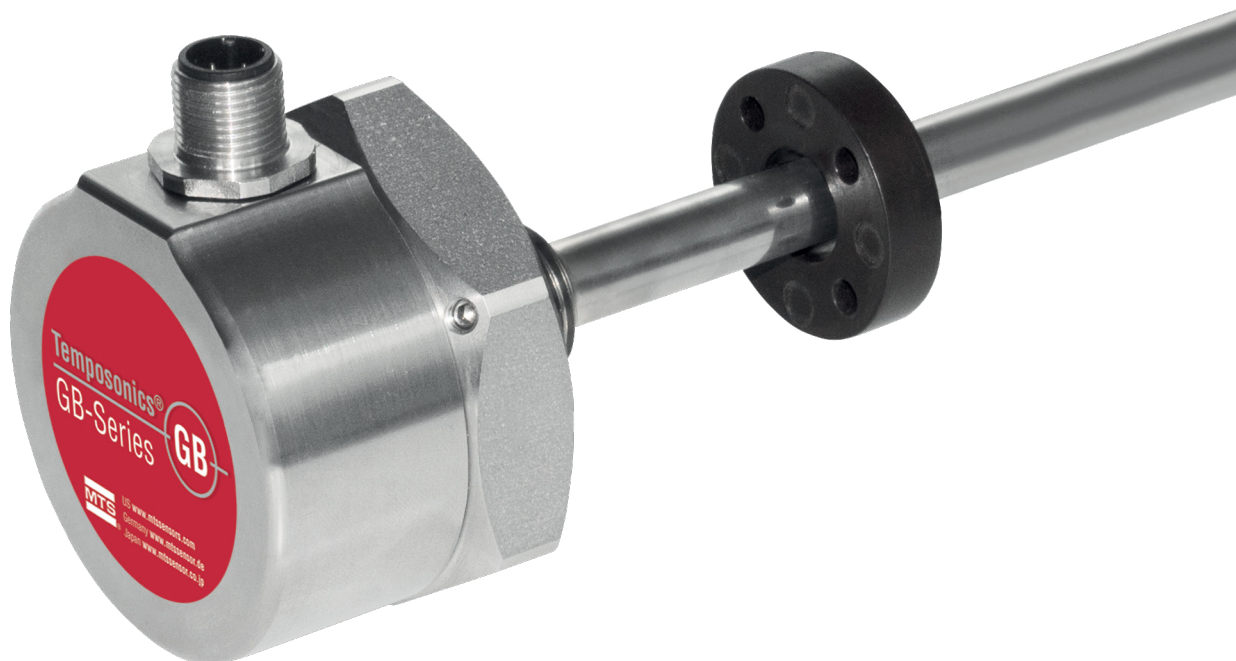

## MEASURING TECHNOLOGY

The absolute, linear position sensors provided by MTS Sensors rely on the company's proprietary Temposonics® magnetostrictive technology, which can determine position with a high level of precision and robustness. Each Temposonics® position sensor consists of a ferromagnetic waveguide, a position magnet, a strain pulse converter and supporting electronics. The magnet, connected to the object in motion in the application, generates a magnetic field at its location on the waveguide. A short current pulse is applied to the waveguide. This creates a momentary radial magnetic field and torsional strain on the waveguide. The momentary interaction of the magnetic fields releases a torsional strain pulse that propagates the length of the waveguide. When the ultrasonic wave reaches the end of the waveguide it is converted into an electrical signal. Since the speed of the ultrasonic wave in the waveguide is precisely known, the time required to receive the return signal can be converted into a linear position measurement with both high accuracy and repeatability.

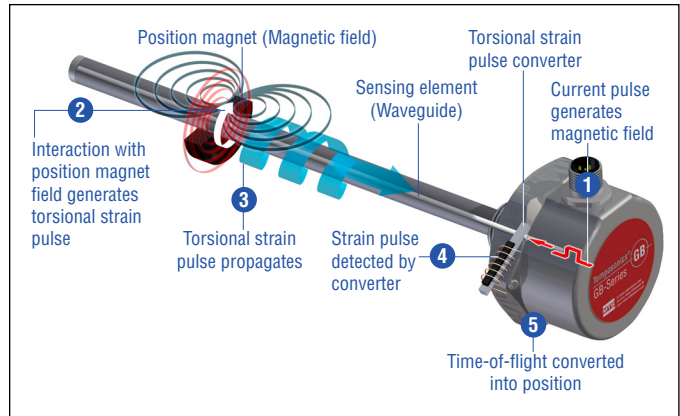

Fig. 1: Time-of-flight based magnetostrictive position sensing principle

## GB-M / GB-T SENSOR

Robust, non-contact and wear free, the Temposonics® linear position sensors provide the best durability and accurate position measurement solutions in harsh industrial environments. The position measurement accuracy is tightly controlled by the quality of the waveguide which is manufactured by MTS Sensors. The position magnet is mounted on the moving machine part and travels non-contact over the sensor rod with the built-in waveguide.

The GB-M / GB-T is an extension of the GB-Series. Its compact housing can be easily mounted, even if there is only limited space. Due to the high temperature resistance, no measures for cooling the sensor have to be taken – saving you time and work. Further advantages of the GB-M / GB-T sensor are:

### TURN ME.

The sensor electronics housing with its electrical connection can be rotated 360 degrees after mounting to easily achieve the necessary connection orientation.



### REPLACE ME.

If needed, the sensor element and electronics can be replaced without interrupting the hydraulic circuit – resulting in lower maintenance costs and reduced downtime.

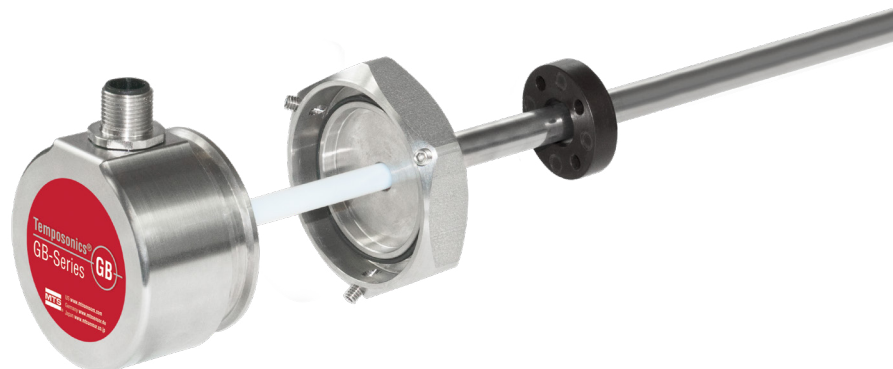

### PROGRAM ME.

The start position and end position of the measurement range are programmable, e.g. via programming kit, allowing users to adjust to meet the application requirements.



## TECHNICAL DATA

Output	
Voltage	0...10 VDC and 10...0 VDC (minimum load controller: > 5 kΩ)
Current	4(0)...20 mA or 20...4(0) mA (minimum/maximum load: 0 / 500 Ω)
Programming	Programming of set points using optional accessories
Measured value	Position
Measurement parameters	
Resolution	16 bit (minimum 1 μm depending on stroke length) <sup>1</sup>
Cycle time	≤ 1200 mm: 0.5 ms ≤ 2400 mm: 1.0 ms > 2400 mm: 2.0 ms
Linearity <sup>2</sup>	≤ ±0.02 % F.S. (minimum ±60 μm) typical
Repeatability	≤ ±0.005 % F.S. (minimum ±20 μm) typical
Operating conditions	
Operating temperature	−40...+90 °C (−40...+194 °F); options: −40...+75 °C (+167 °F)/−40...+100 °C (+212 °F)
Ingress protection	IP67 (if mating connectors are correctly fitted) IP68 (for cable outlet)
Shock test	100 g (single shock), IEC standard 60068-2-27
Vibration test	15 g/10...2000 Hz, IEC standard 60068-2-6 (resonance frequencies excluded)
EMC test	Electromagnetic emission according to EN 61000-6-4 Electromagnetic immunity according to EN 61000-6-2 The sensor meets the requirements of the EU directives and is marked with <b>CE</b>
Operating pressure	350 bar (5076 psi), 700 bar (10153 psi) peak (at 10 × 1 min)
Magnet movement velocity	Any
Design / Material	
Sensor electronics housing <sup>3</sup>	Stainless steel 1.4305 (AISI 303)
Flange	Stainless steel 1.4305 (AISI 303)
Sensor rod	Stainless steel 1.4306; 1.4307 (AISI 304L)
Stroke length	25...3250 mm (1...128 in.)
Mechanical mounting	
Mounting position	Any
Mounting instruction	Please consult the technical drawings and the operation manual (document number: <a href="#">551511</a> )
Electrical connection	
Connection type	M12 (5 pin) male connector M16 (6 pin) male connector Cable outlet
Operating voltage	+24 VDC (−15/+20 %)
Ripple	≤ 0.28 V <sub>pp</sub>
Current consumption	100 mA typical, dependent on stroke length
Dielectric strength	500 VDC (DC ground to machine ground)
Polarity protection	Up to −30 VDC
Overvoltage protection	Up to 36 VDC

1/ The internal digital value is measured through a 16-bit D/A converter and transferred into a proportional, analog current or voltage signal

2/ With position magnet # 251 416-2

3/ For option **H** (−40...+100 °C / −40...+212 °F) an aluminum cover plate is used

## TECHNICAL DRAWING

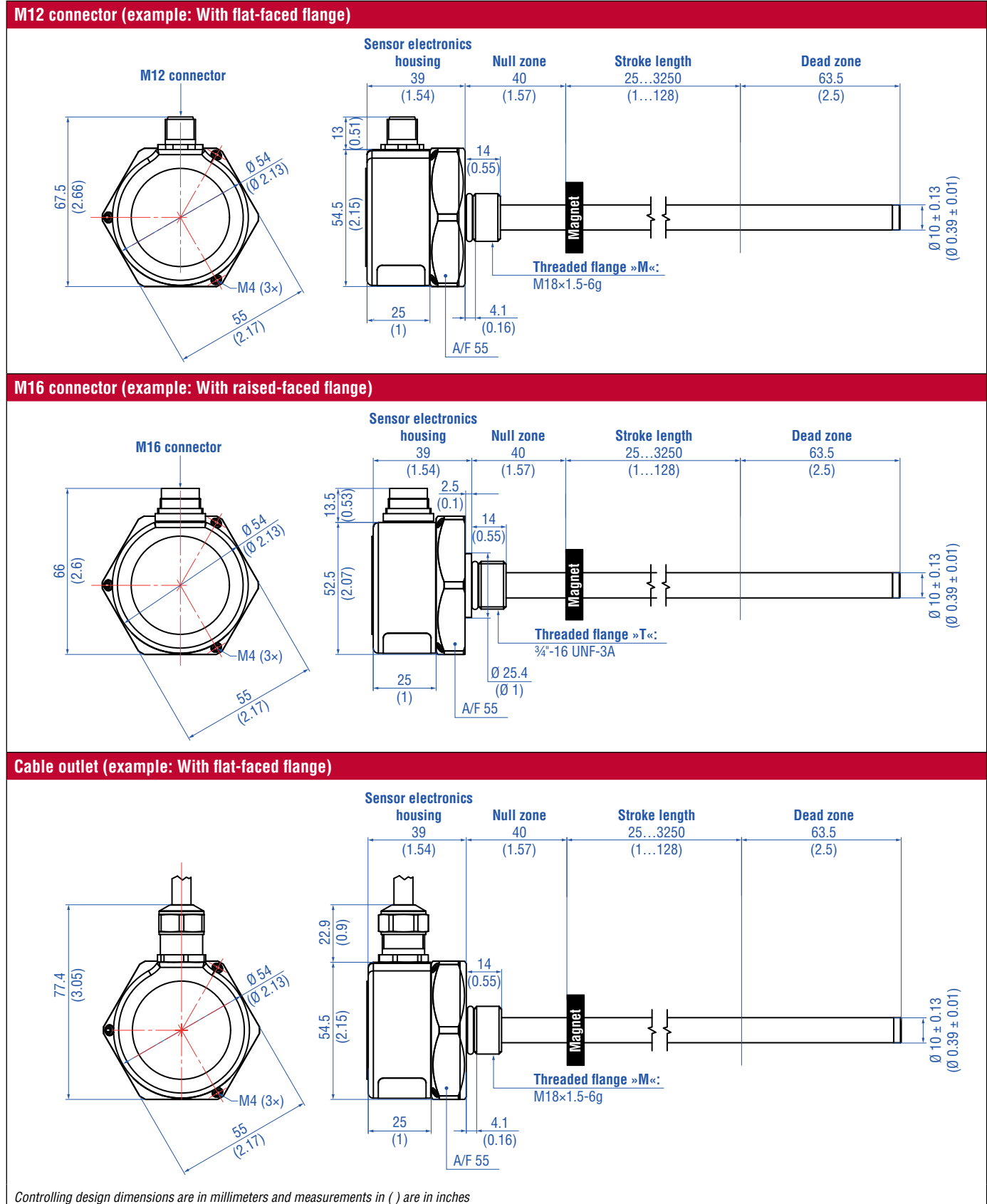

Fig. 2: Temposonics® GB-M / GB-T with ring magnet

## CONNECTOR WIRING

D34 (for outputs: V0, A0, A1, A2, A3 in order code)			
Signal + power supply			
M12 male connector (A-coded)	Pin	Voltage	Current
 <p>View on sensor</p>	1	+24 VDC (-15 / +20 %)	+24 VDC (-15 / +20 %)
	2	0...10 VDC	4(0)...20 mA or 20... 4(0) mA
	3	DC Ground (0 V)	DC Ground (0 V)
	4	10...0 VDC	Not connected <sup>4</sup>
	5	DC Ground	DC Ground

Fig. 3: Connector wiring D34 (M12) for outputs V0, A0, A1, A2 and A3

D34 (for output: A4 in order code)		
Signal + power supply		
M12 male connector (A-coded)	Pin	Current
 <p>View on sensor</p>	1	+24 VDC (-15 / +20 %)
	2	4...20 mA <sup>5</sup>
	3	DC Ground (0 V)
	4	20...4 mA
	5	DC Ground

Fig. 6: Connector wiring D34 (M12) for output A4

D60 (for outputs: V0, A0, A1, A2, A3 in order code)			
Signal + power supply			
M16 male connector	Pin	Voltage	Current
 <p>View on sensor</p>	1	0...10 VDC	4(0)...20 mA or 20... 4(0) mA
	2	DC Ground	DC Ground
	3	10...0 VDC	Not connected <sup>4</sup>
	4	DC Ground	DC Ground
	5	+24 VDC (-15 / +20 %)	+24 VDC (-15 / +20 %)
	6	DC Ground (0 V)	DC Ground (0 V)

Fig. 4: Connector wiring D60 (M16) for outputs V0, A0, A1, A2 and A3

D60 (for output: A4 in order code)		
Signal + power supply		
M16 male connector	Pin	Current
 <p>View on sensor</p>	1	4...20 mA <sup>5</sup>
	2	DC Ground
	3	20...4 mA
	4	DC Ground
	5	+24 VDC (-15 / +20 %)
	6	DC Ground (0 V)

Fig. 7: Connector wiring D60 (M16) for output A4

HXX / TXX / VXX (for outputs: V0, A0, A1, A2, A3 in order code)			
Signal + power supply			
Cable	Color	Voltage	Current
	GY	0...10 VDC	4(0)...20 mA or 20... 4(0) mA
	PK	DC Ground	DC Ground
	YE	10...0 VDC	Not connected <sup>4</sup>
	GN	DC Ground	DC Ground
	BN	+24 VDC (-15 / +20 %)	+24 VDC (-15 / +20 %)
	WH	DC Ground (0 V)	DC Ground (0 V)

Fig. 5: Connector wiring cable outlet for outputs V0, A0, A1, A2 and A3

HXX / TXX / VXX (for output: A4 in order code)		
Signal + power supply		
Cable	Color	Current
	GY	4...20 mA <sup>5</sup>
	PK	DC Ground
	YE	20...4 mA
	GN	DC Ground
	BN	+24 VDC (-15 / +20 %)
	WH	DC Ground (0 V)

Fig. 8: Connector wiring cable outlet for output A4

<sup>4/</sup> Connection necessary for programming with hand or cabinet programmer

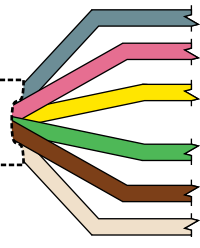
<sup>5/</sup> Connect the first output at low-resistance

**FREQUENTLY ORDERED ACCESSORIES** – Additional options available in our [Accessories Guide](#)  [551444](#)

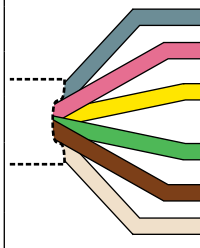
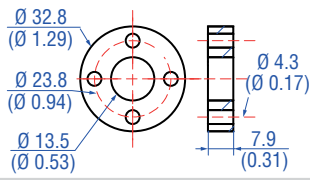
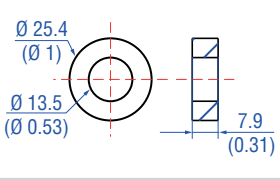
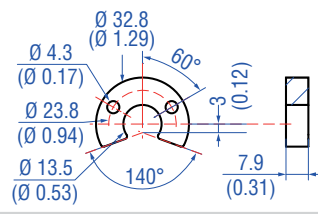
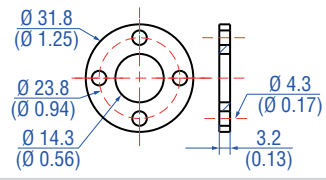
Position magnets		Magnet spacer	
 <p>Technical drawing of Ring magnet OD33 showing dimensions: outer diameter 32.8 (1.29), inner diameter 23.8 (0.94), hole diameter 13.5 (0.53), hole offset 4.3 (0.17), and thickness 7.9 (0.31).</p>	 <p>Technical drawing of Ring magnet OD25.4 showing dimensions: outer diameter 25.4 (1), inner diameter 13.5 (0.53), and thickness 7.9 (0.31).</p>	 <p>Technical drawing of U-magnet OD33 showing dimensions: outer diameter 32.8 (1.29), hole diameter 23.8 (0.94), hole diameter 13.5 (0.53), hole offset 4.3 (0.17), thickness 7.9 (0.31), and a 140-degree arc.</p>	 <p>Technical drawing of Magnet spacer showing dimensions: outer diameter 31.8 (1.25), inner diameter 23.8 (0.94), hole diameter 14.3 (0.56), hole offset 4.3 (0.17), and thickness 3.2 (0.13).</p>
<p><b>Ring magnet OD33</b> Part no. 201 542-2</p> <p>Material: PA ferrite GF20 Weight: Approx. 14 g Surface pressure: Max. 40 N/mm<sup>2</sup> Fastening torque for M4 screws: 1 Nm Operating temperature: -40...+105 °C (-40...+221 °F)</p>	<p><b>Ring magnet OD25.4</b> Part no. 400 533</p> <p>Material: PA ferrite Weight: Approx. 10 g Surface pressure: Max. 40 N/mm<sup>2</sup> Operating temperature: -40...+105 °C (-40...+221 °F)</p>	<p><b>U-magnet OD33</b> Part no. 251 416-2</p> <p>Material: PA ferrite GF20 Weight: Approx. 11 g Surface pressure: Max. 40 N/mm<sup>2</sup> Fastening torque for M4 screws: 1 Nm Operating temperature: -40...+105 °C (-40...+221 °F)</p>	<p><b>Magnet spacer</b> Part no. 400 633</p> <p>Material: Aluminum Weight: Approx. 5 g Surface pressure: Max. 20 N/mm<sup>2</sup> Fastening torque for M4 screws: 1 Nm</p>

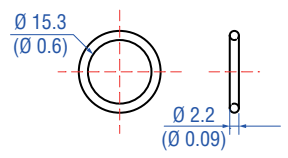
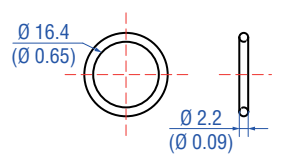
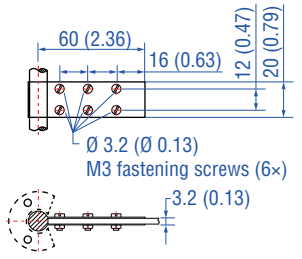
O-rings		Optional installation hardware
 <p>Technical drawing of O-ring for threaded flange M18x1.5-6g showing dimensions: outer diameter 15.3 (0.6) and thickness 2.2 (0.09).</p>	 <p>Technical drawing of O-ring for threaded flange 3/4-16 UNF-3A showing dimensions: outer diameter 16.4 (0.65) and thickness 2.2 (0.09).</p>	 <p>Technical drawing of Fixing clip showing dimensions: length 60 (2.36), hole diameter 3.2 (0.13), and hole offset 16 (0.63). It also shows a detail of the clip with 6 M3 fastening screws.</p>
<p><b>O-ring for threaded flange</b> M18x1.5-6g Part no. 401 133</p> <p>Material: Fluoroelastomer Durometer: 75 ± 5 Shore A Operating temperature: -40...+204 °C (-40...+400 °F)</p>	<p><b>O-ring for threaded flange</b> 3/4"-16 UNF-3A Part no. 560 315</p> <p>Material: Fluoroelastomer Durometer: 75 ± 5 Shore A Operating temperature: -40...+204 °C (-40...+400 °F)</p>	<p><b>Fixing clip</b> Part no. 561 481</p> <p>Application: Used to secure sensor rods (Ø 10 mm (Ø 0.39 in.)) when using an U-magnet or block magnet Material: Brass, non-magnetic</p>

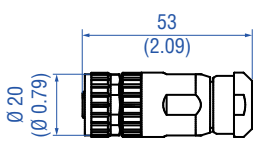
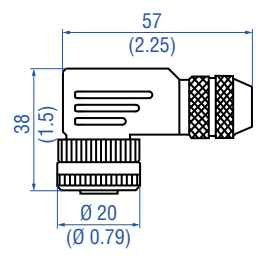
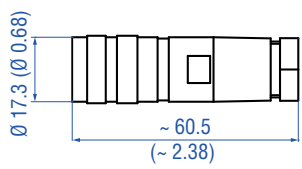
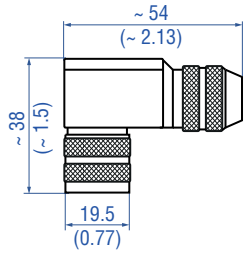
Cable connectors <sup>6</sup>			
 <p>Technical drawing of M12 A-coded female connector (4 pin/5 pin), straight showing dimensions: length 53 (2.09) and cable diameter 20 (0.79).</p>	 <p>Technical drawing of M12 A-coded female connector (5 pin), angled showing dimensions: length 57 (2.25), cable diameter 20 (0.79), and angled length 38 (1.5).</p>	 <p>Technical drawing of M16 female connector (6 pin), straight showing dimensions: length ~60.5 (~2.38) and cable diameter 17.3 (0.68).</p>	 <p>Technical drawing of M16 female connector (6 pin), angled showing dimensions: length ~54 (~2.13), cable diameter 19.5 (0.77), and angled length ~38 (~1.5).</p>
<p><b>M12 A-coded female connector</b> (4 pin/5 pin), straight Part no. 370 677</p> <p>Material: GD-Zn, Ni Termination: Screw Contact insert: CuZn Cable Ø: 4...8 mm (0.16...0.31 in.) Wire: 1.5 mm<sup>2</sup> Operating temperature: -30...+85 °C (-22...+185 °F) Ingress protection: IP67 (correctly fitted) Fastening torque: 0.6 Nm</p>	<p><b>M12 A-coded female connector</b> (5 pin), angled Part no. 370 678</p> <p>Material: GD-Zn, Ni Termination: Screw; max. 0.75 mm<sup>2</sup> Contact insert: CuZn Cable Ø: 5...8 mm (0.2...0.31 in.) Wire: 0.75 mm<sup>2</sup> (18 AWG) Operating temperature: -25...+85 °C (-13...+185 °F) Ingress protection: IP67 (correctly fitted) Fastening torque: 0.4 Nm</p>	<p><b>M16 female connector (6 pin), straight</b> Part no. 370 423</p> <p>Material: Zinc nickel plated Termination: Solder Cable Ø: 6...8 mm (0.24...0.31 in.) Operating temperature: -40...+100 °C (-40...+212 °F) Ingress protection: IP65/IP67 (correctly fitted) Fastening torque: 0.6 Nm</p>	<p><b>M16 female connector (6 pin), angled</b> Part no. 370 460</p> <p>Material: Zinc nickel plated Termination: Solder Cable Ø: 6...8 mm (0.24...0.31 in.) Wire: 0.75 mm<sup>2</sup> (20 AWG) Operating temperature: -40...+95 °C (-40...+203 °F) Ingress protection: IP67 (correctly fitted) Fastening torque: 0.6 Nm</p>

<sup>6/</sup> Follow the manufacturer's mounting instructions when connecting the connectors

## Cables

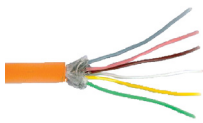

**PUR cable**  
Part no. 530 052

Name of cable in order code: **H**  
Material: PUR jacket; orange  
Features: Twisted pair, shielded, highly flexible, halogen free, suitable for drag chains, mostly oil & flame resistant  
Cable Ø: 6.4 mm (0.25 in.)  
Cross section:  $3 \times 2 \times 0.25 \text{ mm}^2$   
Bending radius:  $5 \times D$  (fixed installation)  
Operating temperature:  $-30 \dots +80 \text{ °C}$  ( $-22 \dots +176 \text{ °F}$ )

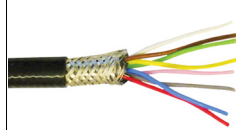

**Teflon® cable**  
Part no. 530 112

Name of cable in order code: **T**  
Material: Teflon® jacket; black  
Features: Twisted pair, shielded, flexible, high thermal resistance, mostly oil & acid resistant  
Cable Ø: 7.6 mm (0.3 in.)  
Cross section:  $4 \times 2 \times 0.25 \text{ mm}^2$   
Bending radius:  $8 - 10 \times D$  (fixed installation)  
Operating temperature:  $-100 \dots +180 \text{ °C}$  ( $-148 \dots +356 \text{ °F}$ )



**Silicone cable**  
Part no. 530 113

Name of cable in order code: **V**  
Material: Silicone jacket; red  
Features: Twisted pair, shielded, highly flexible, halogen free, high thermal resistance  
Cable Ø: 7.2 mm (0.28 in.)  
Cross section:  $3 \times 2 \times 0.25 \text{ mm}^2$   
Bending radius:  $5 \times D$  (fixed installation)  
Operating temperature:  $-50 \dots +180 \text{ °C}$  ( $-58 \dots +356 \text{ °F}$ )

## Programming tools



**Hand programmer for analog output**  
Part no. 253 124

Easy teach-in-setups of stroke length and direction on desired zero / span positions. For sensors with 1 magnet.



**Cabinet programmer for analog output**  
Part no. 253 408

Features snap-in mounting on standard DIN rail (35 mm). This programmer can be permanently mounted in a control cabinet and includes a program/run switch. For sensors with 1 magnet.



**Programming kit**  
Part no. 254 555

Kit includes:  
1 × interface converter box  
1 × power supply  
1 × cable (60 cm) with M12 female connector (5 pin), straight – D-sub female connector (9 pin), straight  
1 × cable (60 cm) with M16 female connector (6 pin), straight – D-sub female connector (9 pin), straight  
1 × cable (60 cm) with 3 × terminal clamp – D-sub female connector (9 pin), straight  
1 × USB cable

Software is available at:  
[www.mtssensors.com](http://www.mtssensors.com)

## ORDER CODE

1	2	3	4	5	6	7	8	9	10	11	12	13	14	15	16
G	B										1				C
a	b	c						d	e	f	g	h			

a	Sensor model
G B	Rod

b	Design
B	Base unit for threaded flanges »M« and »T«
<b>GB rod-style sensor with housing material 1.4305 (AISI 303) and rod material 1.4306 / 1.4307 (AISI 304L)</b>	
M	Threaded flange with flat-face, M18×1.5-6g
T	Threaded flange with raised-faced, ¾"-16 UNF-3A

c	Stroke length	
X X X X M	0025...3250 mm	
X X X X U	001.0...128.0 in.	
Standard stroke length (mm)*		Ordering steps
25... 500 mm		5 mm
500... 750 mm		10 mm
750...1000 mm		25 mm
1000...2500 mm		50 mm
2500...3250 mm		100 mm
Standard stroke length (in.)*		Ordering steps
1... 20 in.		0.2 in.
20... 30 in.		0.5 in.
30... 40 in.		1.0 in.
40...100 in.		2.0 in.
100...128 in.		4.0 in.

d	Connection type
D 3 4	M12 (5 pin) male connector (Note the operating temperature of the connector)
D 6 0	M16 (6 pin) male connector (Note the operating temperature of the connector)
H X X	H01...H10 (1...10 m) <sup>7</sup> PUR cable (part no. 530 052) H03...H33 (3...33 ft) <sup>7</sup> PUR cable (part no. 530 052) (Note the operating temperature of the cable)
T X X	T01...T10 (1...10 m) <sup>7</sup> Teflon® cable (part no. 530 112) T03...T33 (3...33 ft) <sup>7</sup> Teflon® cable (part no. 530 112)
V X X	V01...V10 (1...10 m) <sup>7</sup> Silicone cable (part no. 530 113) V03...V33 (3...33 ft) <sup>7</sup> Silicone cable (part no. 530 113)

e	Operating voltage
1	+24 VDC (-15 / +20 %)

f	Output
V 0	0...10 VDC and 10...0 VDC
A 0	4...20 mA
A 1	20...4 mA
A 2	0...20 mA
A 3	20...0 mA
A 4	4...20 mA and 20...4 mA

g	Operating temperature
H	-40...+100 °C (-40...+212 °F)
S	-40...+90 °C (-40...+194 °F)
L	-40...+75 °C (-40...+167 °F)

h	Programming
C	Via cable

## DELIVERY

	<b>GB-B:</b> Sensor	<b>GB-M / GB-T:</b> Sensor O-ring	Accessories have to be ordered separately.
---	------------------------	---	--

Manuals, Software & 3D Models available at:  
[www.mtssensors.com](http://www.mtssensors.com)

\* / Non standard stroke lengths are available; must be encoded in 5 mm / 0.1 in. increments

<sup>7</sup> Encode in meters if using metric stroke length. Encode in feet if using US customary stroke length

Trademarks and trade names are those of their respective owners.



**UNITED STATES** 3001 Sheldon Drive  
**MTS Systems Corporation** Cary, N.C. 27513  
**Sensors Division** Phone: +1 919 677-0100  
Americas & APAC Region E-mail: info.us@mtssensors.com

---

**GERMANY** Auf dem Schüffel 9  
**MTS Sensor Technologie** 58513 Lüdenscheid  
**GmbH & Co. KG** Phone: +49 2351 9587-0  
EMEA Region & India E-mail: info.de@mtssensors.com

---

**ITALY** Phone: +39 030 988 3819  
Branch Office E-mail: info.it@mtssensors.com

---

**FRANCE** Phone: +33 1 58 4390-28  
Branch Office E-mail: info.fr@mtssensors.com

---

**UK** Phone: +44 79 44 15 03 00  
Branch Office E-mail: info.uk@mtssensors.com

---

**SCANDINAVIA** Phone: +46 70 29 91 281  
Branch Office E-mail: info.sca@mtssensors.com

---

**CHINA** Phone: +86 21 2415 1000 / 2415 1001  
Branch Office E-mail: info.cn@mtssensors.com

---

**JAPAN** Phone: +81 3 6416 1063  
Branch Office E-mail: info.jp@mtssensors.com

---

**Document Part Number:**  
551838 Revision B (EN) 05/2021



[www.mtssensors.com](http://www.mtssensors.com)

# Temposonics®

Magnetostrictive Linear Position Sensors

## GB-M / GB-T SSI Data Sheet

- Sensor element and electronics can be changed
- Flat & compact sensor electronics housing
- Electrical connection is freely rotatable

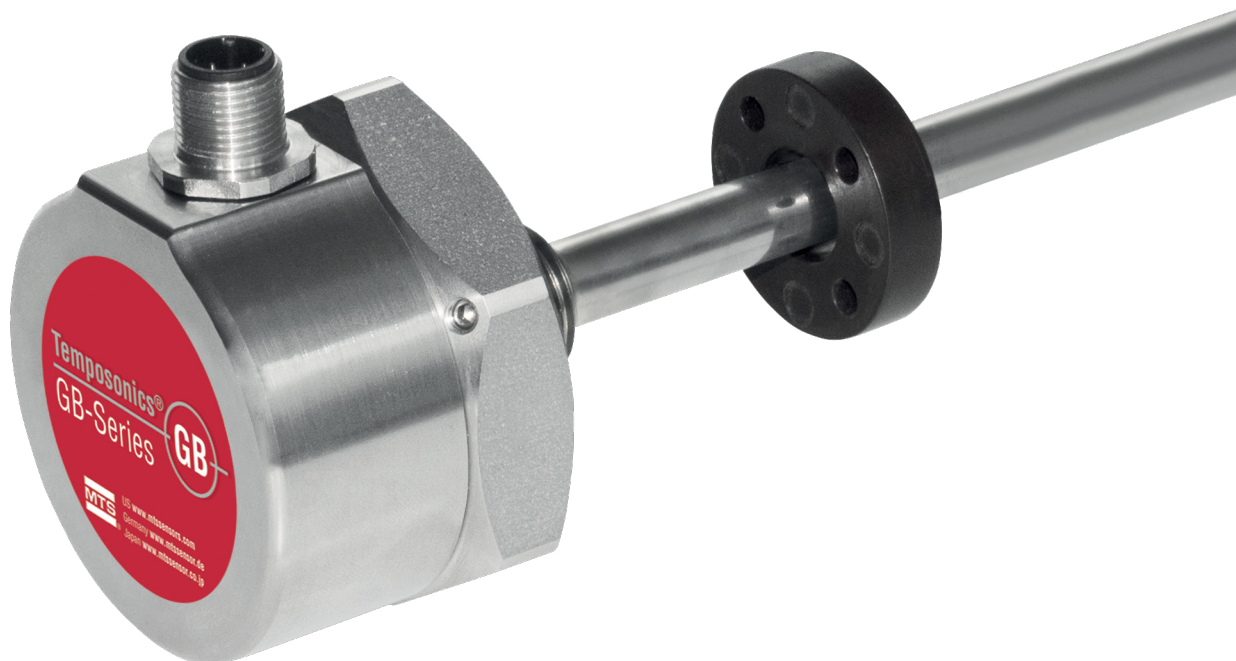

## MEASURING TECHNOLOGY

The absolute, linear position sensors provided by MTS Sensors rely on the company's proprietary Temposonics® magnetostrictive technology, which can determine position with a high level of precision and robustness. Each Temposonics® position sensor consists of a ferromagnetic waveguide, a position magnet, a strain pulse converter and supporting electronics. The magnet, connected to the object in motion in the application, generates a magnetic field at its location on the waveguide. A short current pulse is applied to the waveguide. This creates a momentary radial magnetic field and torsional strain on the waveguide. The momentary interaction of the magnetic fields releases a torsional strain pulse that propagates the length of the waveguide. When the ultrasonic wave reaches the end of the waveguide it is converted into an electrical signal. Since the speed of the ultrasonic wave in the waveguide is precisely known, the time required to receive the return signal can be converted into a linear position measurement with both high accuracy and repeatability.

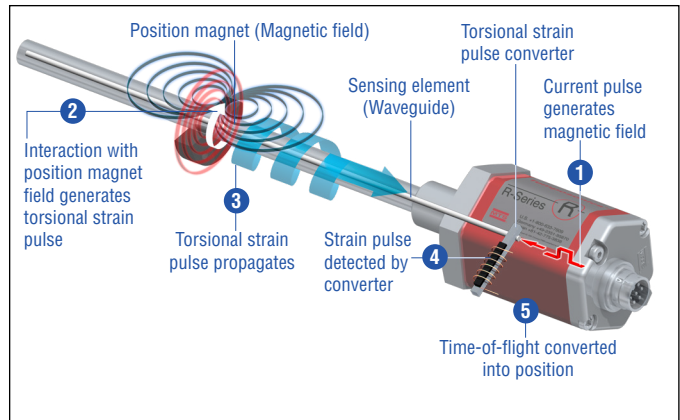

Fig. 1: Time-of-flight based magnetostrictive position sensing principle

## GB-M / GB-T SENSOR

Robust, non-contact and wear free, the Temposonics® linear position sensors provide the best durability and accurate position measurement solutions in harsh industrial environments. The position measurement accuracy is tightly controlled by the quality of the waveguide which is manufactured by MTS Sensors. The position magnet is mounted on the moving machine part and travels non-contact over the sensor rod with the built-in waveguide.

The GB-M / GB-T is an extension of the GB-Series. Its compact housing can be easily mounted, even if there is only limited space. Due to the high temperature resistance, no measures for cooling the sensor have to be taken – saving you time and work. Further advantages of the GB-M / GB-T sensor are:



### TURN ME.

The sensor electronics housing with its electrical connection can be rotated 360 degrees after mounting to easily achieve the necessary connection orientation.



### REPLACE ME.

If needed, the sensor element and electronics can be replaced without interrupting the hydraulic circuit – resulting in lower maintenance costs and reduced downtime.

### PROGRAM ME.

The start position and end position of the measurement range are programmable, e.g. via programming kit, allowing users to adjust to meet the application requirements.

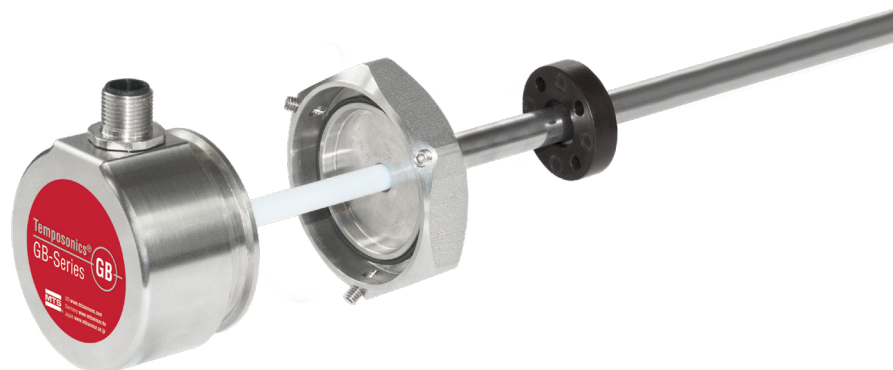

## TECHNICAL DATA

Output	
Interface	SSI (Synchronous Serial Interface) – Differential signal in SSI standard
Data format	Binary, gray
Programming	Programming of set points using optional accessories
Measured value	Position
Measurement parameters	
Resolution	Min. resolution 5 µm
Cycle time	Up to 3.7 kHz depending on stroke length
Linearity	≤ ±0.02 % F.S. (minimum ±60 µm) typically
Repeatability	≤ ±0.005 % F.S. (minimum ±20 µm) typically
Operating conditions	
Operating temperature	–40...+90 °C (–40...+194 °F), option: –40...+100 °C (–40...+212 °F)
Ingress protection	IP67 with proper mating connector IP68 for cable outlet
Shock test	100 g (single shock) IEC standard 60068-2-27
Vibration test	15 g / 10...2000 Hz IEC standard 60068-2-6 (resonance frequencies excluded)
EMC test	Electromagnetic emission according to EN 61000-6-4 Electromagnetic immunity according to EN 61000-6-2 The sensor meets the requirements of the EU directives and is marked with <b>CE</b> .
Magnet movement velocity	Any
Design/Material	
Sensor electronics housing <sup>1</sup>	Stainless steel 1.4305 (AISI 303)
Sensor rod	Stainless steel 1.4306; 1.4307 (AISI 304L)
Stroke length	25...3250 mm (1...128 in.)
Operating pressure	350 bar (5076 psi), 700 bar (10153 psi) peak (at 10 × 1 min)
Mechanical mounting	
Mounting position	Any
Mounting instruction	Please consult the technical drawings and the operation manual (document number: <a href="#">551631</a> )
Electrical connection	
Connection type	M12 (8 pin) male connector A-coded M16 (7 pin) male connector Cable outlet
Operating voltage	+24 VDC (–15 / +20 %)
Ripple	≤ 0.28 V <sub>pp</sub>
Current consumption	90 mA typically
Dielectric strength	500 VDC (DC ground to machine ground)
Polarity protection	Up to –30 VDC
Overvoltage protection	Up to 36 VDC

<sup>1/</sup> For option **H** (–40...+100 °C / –40...+212 °F) an aluminum cover plate is used

## TECHNICAL DRAWING

### M12 connector (Example: With flat-faced flange)

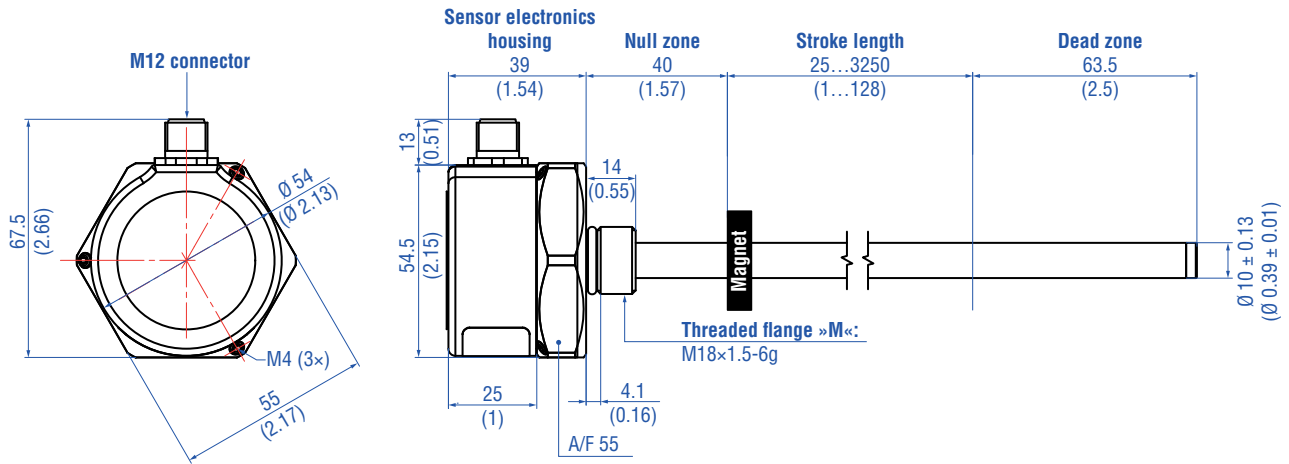

### M16 connector (Example: With raised-faced flange)

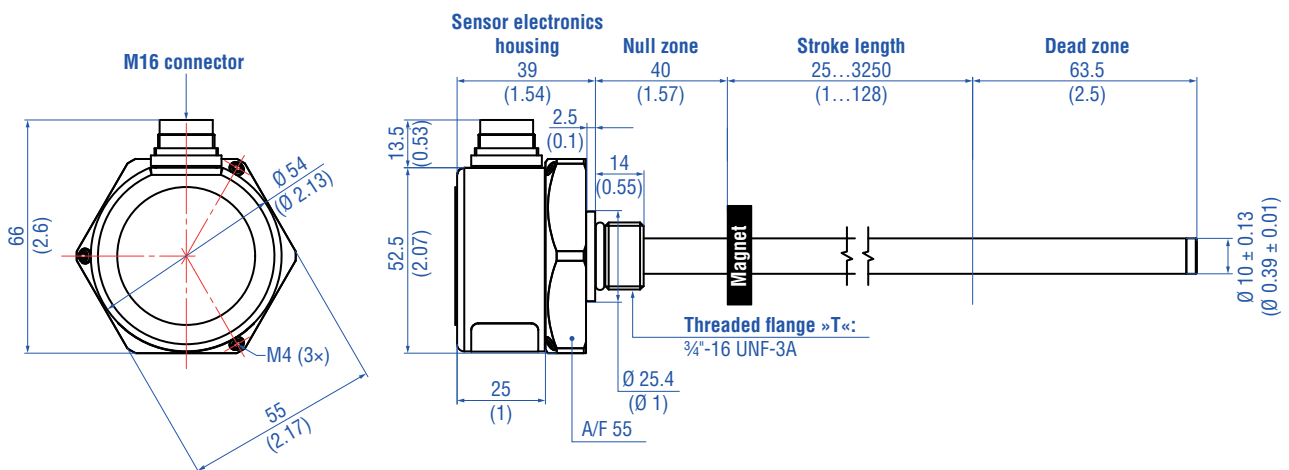

### Cable outlet (Example: With flat-faced flange)

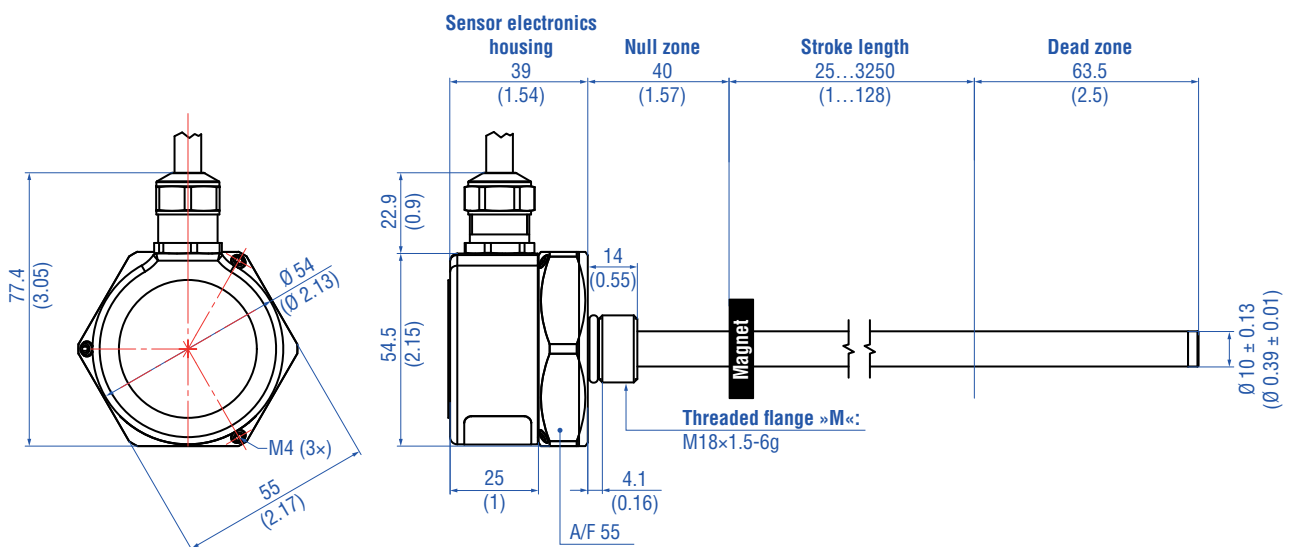

Controlling design dimensions are in millimeters and measurements in ( ) are in inches  
Unless otherwise stated, apply to the general tolerances according to DIN ISO 2768-m

## CONNECTOR WIRING

### M12 connector

D84	Pin	Function
	1	Clock (+)
	2	Clock (-)
	3	Data (+)
	4	Data (-)
	5	Not connected
	6	Not connected
	7	+24 VDC (-15 / +20 %)
	8	DC Ground (0 V)

### M16 connector

D70	Pin	Function
	1	Data (-)
	2	Data (+)
	3	Clock (+)
	4	Clock (-)
	5	+24 VDC (-15 / +20 %)
	6	DC Ground (0 V)
	7	Not connected



### Cable outlet

Cable	Function
GY	Data (-)
PK	Data (+)
YE	Clock (+)
GN	Clock (-)
BN	+24 VDC (-15 / +20 %)
WH	DC Ground (0 V)

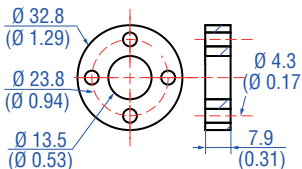
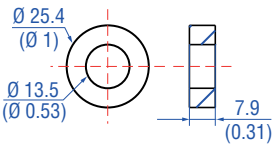
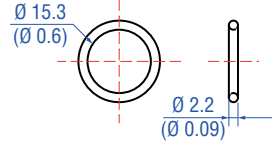
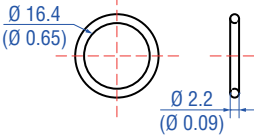
**FREQUENTLY ORDERED ACCESSORIES** – Additional options available in our [Accessories Guide](#)  [551444](#)

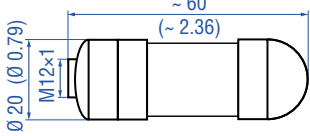
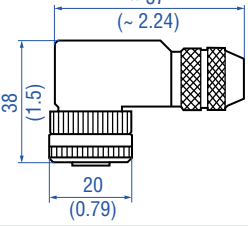
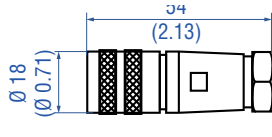
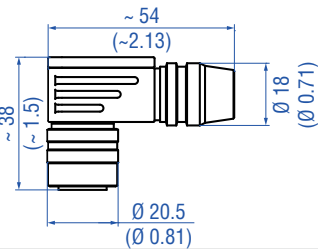
Position magnets		O-rings	
			
<b>Ring magnet OD33</b> Part no. 201 542-2	<b>Ring magnet OD25.4</b> Part no. 400 533	<b>O-ring for threaded flange M18x1.5-6g</b> Part no. 401 133	<b>O-ring for threaded flange 3/4-16 UNF-3A</b> Part no. 560 315
Material: PA ferrite GF20 Weight: Approx. 14 g Surface pressure: Max. 40 N/mm <sup>2</sup> Fastening torque for M4 screws: 1 Nm Operating temperature: -40...+105 °C (-40...+221 °F)	Material: PA ferrite Weight: Approx. 10 g Surface pressure: Max. 40 N/mm <sup>2</sup> Operating temperature: -40...+105 °C (-40...+221 °F)	Material: Fluoroelastomer Durometer: 75 ± 5 Shore A Operating temperature: -40...+204 °C (-40...+400 °F)	Material: Fluoroelastomer Durometer: 75 ± 5 Shore A Operating temperature: -40...+204 °C (-40...+400 °F)

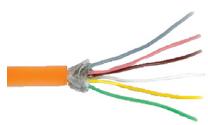
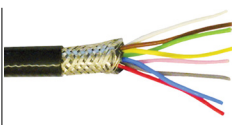
Cable connectors <sup>3</sup>			
			
<b>M12 A-coded female connector (8 pin), straight</b> Part no. 370 694	<b>M12 A-coded female connector (8 pin), angled</b> Part no. 370 699	<b>M16 female connector (7 pin), straight</b> Part no. 370 624	<b>M16 female connector (7 pin), angled</b> Part no. 560 779
Housing: GD-ZnAL Termination: Screw Contact insert: CuZn Cable Ø: 4...9 mm (0.16...0.35 in.) Wire: 0.75 mm <sup>2</sup> Operating temperature: -25...+90 °C (-13...+194 °F) Ingress protection: IP67 (correctly fitted) Fastening torque: 0.6 Nm	Housing: GD-ZnAL Termination: Screw Contact insert: CuZn Cable Ø: 6...8 mm (0.24...0.31 in.) Wire: 0.5 mm <sup>2</sup> Operating temperature: -25...+85 °C (-13...+185 °F) Ingress protection: IP67 (correctly fitted) Fastening torque: 0.6 Nm	Material: Zinc nickel plated Termination: Solder Contact insert: Silver plated Cable clamp: PG9 Cable Ø: 6...8 mm (0.24...0.31 in.) Operating temperature: -40...+100 °C (-40...+212 °F) Ingress protection: IP65 / IP67 (correctly fitted) Fastening torque: 0.7 Nm	Material: Zinc nickel plated Termination: Solder Contact insert: Silver plated Cable Ø: 6...8 mm (0.24...0.31 in.) Wire: 0.75 mm <sup>2</sup> (20 AWG) Operating temperature: -40...+95 °C (-40...+203 °F) Ingress protection: IP67 (correctly fitted) Fastening torque: 0.5 Nm

Cables			Programming tools
			
<b>PUR cable</b> Part no. 530 052	<b>Teflon® cable</b> Part no. 530 112	<b>Silicone cable</b> Part no. 530 113	<b>Programming kit</b> Part no. 254 590
Material: PUR jacket; orange Features: Twisted pair, shielded, highly flexible Cable Ø: 6.4 mm (0.25 in.) Cross section: 3 × 2 × 0.25 mm <sup>2</sup> Bending radius: 5 × Ø (fixed insulation) Operating temperature: -30...+80 °C (-22...+176 °F)	Material: Teflon® jacket; black Features: Twisted pair, shielded, flexible Cable Ø: 7.6 mm (0.3 in.) Cross section: 4 × 2 × 0.25 mm <sup>2</sup> Bending radius: 8 – 10 × Ø (fixed installation) Operating temperature: -100...+180 °C (-148...+356 °F)	Material: Silicone jacket; red Features: Twisted pair, shielded, highly flexible Cable Ø: 7.2 mm (0.28 in.) Cross section: 3 × 2 × 0.25 mm <sup>2</sup> Bending radius: 5 × Ø (fixed installation) Operating temperature: -50...+180 °C (-58...+356 °F)	Kit includes: 1 × interface converter box, 1 × power supply 1 × cable (60 cm) with M12 female connector (8 pin), straight – D-sub female connector (9 pin), straight 1 × cable (60 cm) with M16 female connector (7 pin), straight – D-sub female connector (9 pin), straight 1 × cable (60 cm) with 6 × terminal clamp – D-sub female connector (9 pin), straight 1 × USB cable

Controlling design dimensions are in millimeters and measurements in ( ) are in inches

2/ Follow the manufacturer's mounting instructions when connecting the connectors

## ORDER CODE

1	2	3	4	5	6	7	8	9	10	11	12	13	14	15	16	17	18	19	20	21
G	B										1	S								C
a	b	c						d	e	f						g	h			

<b>a</b>	<b>Sensor model</b>
G B	Rod

<b>b</b>	<b>Design</b>
B	Base unit for flange »M« and flange »T«
M	Flat-faced flange, M18×1.5-6g
T	Raised-faced flange, ¼"-16 UNF-3A

<b>c</b>	<b>Stroke length</b>
X X X X M	0025...3250 mm
X X X X U	001.0...128.0 in.

### Standard stroke length (mm) \*

Stroke length	Ordering steps
25... 500 mm	5 mm
500... 750 mm	10 mm
750...1000 mm	25 mm
1000...2500 mm	50 mm
2500...3250 mm	100 mm

### Standard stroke length (in.) \*

Stroke length	Ordering steps
1... 20 in.	0.2 in.
20... 30 in.	0.5 in.
30... 40 in.	1.0 in.
40...100 in.	2.0 in.
100...128 in.	4.0 in.

<b>d</b>	<b>Connection type</b>
D 8 4	M12 (8 pin) male connector
D 7 0	M16 (7 pin) male connector
H X X	PUR cable (part no. 530 052) (suitable for max. operating temperature of +80 °C (+176 °F)) H01...H10 (1...10 m / 3...33 ft) <sup>4</sup> <b>See "Frequently ordered accessories" for cable specifications</b>
T X X	Teflon® cable (part no. 530 112) T01...T10 (1...10 m / 3...33 ft) <sup>4</sup> <b>See "Frequently ordered accessories" for cable specifications</b>
V X X	Silicone cable (part no. 530 113) V01...V10 (1...10 m / 3...33 ft) <sup>4</sup> <b>See "Frequently ordered accessories" for cable specifications</b>

<b>e</b>	<b>Operating voltage</b>
1	+24 VDC (-15 / +20 %)

<b>f</b>	<b>Output</b>
S (14) (15) (16) (17) (18) (19) = Synchronous Serial Interface	
<b>Data length (box no. 14)</b>	
1	25 bit
2	24 bit
<b>Output format (box no. 15)</b>	
B	Binary
G	Gray
<b>Resolution (box no. 16)</b>	
1	0.005 mm
2	0.01 mm
3	0.05 mm
4	0.1 mm
5	0.02 mm
<b>Filter (box no. 17)</b>	
1	No filter
2	Average filter 2
3	Average filter 4
4	Average filter 8
<b>Performance (box no. 18, 19)</b>	
0 0	Measuring direction forward, asynchronous measurement
0 1	Measuring direction reverse, asynchronous measurement
0 2	Measuring direction forward, synchronous measurement
0 3	Measuring direction reverse, synchronous measurement

<b>g</b>	<b>Operating temperature</b>
H	-40...+100 °C (-40...+212 °F)
S	-40...+90 °C (-40...+194 °F)

<b>h</b>	<b>Programming</b>
C	Via cable

## DELIVERY

 <b>GB-B:</b> Sensor	<b>GB-M / GB-T:</b> Sensor O-ring	Accessories have to be ordered separately.
--	---	--

\* / Non standard stroke lengths are available; must be encoded in 5 mm / 0.1 in. increments

3/ Encode in meters if using metric stroke length. Encode in feet if using US customary stroke length.



**UNITED STATES** 3001 Sheldon Drive  
MTS Systems Corporation Cary, N.C. 27513  
Sensors Division Phone: +1 919 677-0100  
E-mail: info.us@mtssensors.com

---

**GERMANY** Auf dem Schüffel 9  
MTS Sensor Technologie 58513 Lüdenscheid  
GmbH & Co. KG Phone: +49 2351 9587-0  
E-mail: info.de@mtssensors.com

---

**ITALY** Phone: +39 030 988 3819  
Branch Office E-mail: info.it@mtssensors.com

---

**FRANCE** Phone: +33 1 58 4390-28  
Branch Office E-mail: info.fr@mtssensors.com

---

**GREAT BRITAIN** Phone: +44 79 44 15 03 00  
Branch Office E-mail: info.uk@mtssensors.com

---

**CHINA** Phone: +86 21 6485 5800  
Branch Office E-mail: info.cn@mtssensors.com

---

**JAPAN** Phone: +81 3 6416 1063  
Branch Office E-mail: info.jp@mtssensors.com

---

**Document Part Number:**  
551839 Revision A (EN) 03/2018



[www.mtssensors.com](http://www.mtssensors.com)