



LOAD CELL INSTRUCTION MANUAL

Thank you for purchasing this KYOWA product. Before using it, read this instruction manual carefully. Also, keep the manual within easy reach so that you can refer to it whenever necessary.

1. Calling the operator's attention

The following cautionary symbols and headlines are used to invite the operator's attention. Be sure to observe the accompanying precautions in order to safeguard the operator and preserve the performance of the instrument.

 Warning	Improper handling may cause serious injury to the operator. To avoid harm, be sure to observe the accompanying instructions.
 Caution	Improper handling may cause deleterious effects to the operator's body. To avoid harm, be sure to observe the accompanying instructions.
Caution	Cautions are given to invite the operator's attention, in order to avoid instrument failure or mal-function. Be sure to observe the accompanying instructions.

2. Safety precautions

Caution

- Do not use the "special accessories" with load cells other than KYOWA.

2.1 Tension load cells

Use special accessories assembled and incorporated into the load cell by KYOWA.

Warning

- Avoid loads in excess of the rated load capacity, or the load cell may rupture. Provide a safety device to prevent the load cell installation from falling.
- Improper locking of the connections may result in disconnection and falling of the load cell installation. To use in combination with the "special accessories for tension load cells", be sure to properly lock all connections beforehand.
- Loose setscrews and nuts may cause disconnection and falling of the load cell installation. Before starting operation check that the setscrews are tight, in order to prevent the load cell installation from falling. If the setscrews are found loose, apply screw-lock then tighten, or contact your KYOWA representative.

2.2 Compression load cells

Caution

- A load cell which is fixed insufficiently may slip when exposed to a lateral load.
- The top of a load cell may collapse when exposed to an excessive load.

3. Applicable load cells

This instruction manual is applicable to the load cells as follow.

- Compression load cells:
LC-A, LC-E, LC-F, LCF-A, LCK-A, LC-FH, LC-FL,
LC-J, LC-G, LC-V, LCV-A

- Tension/compression load cells:
LU-A, LU-E
- Tension load cells:
LT-F, LTF-A, LT-FH, LT-FL, LT-G, LTZ-A

4. Handling precautions

Caution

- Using toluene or acetone, remove the rustproof galvanized coats from the bottom and top of the load cell, respectively.
- Each load cell is designed to detect only the force applied to the central axis. Since installation quality directly affects the measurement accuracy, install it carefully so that an inclined load, angular moment, horizontal force component and bending moment may not affect the load cell.

Good examples

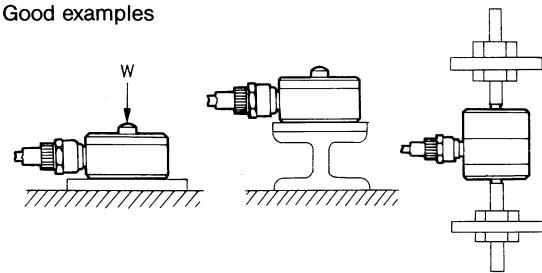

No good examples

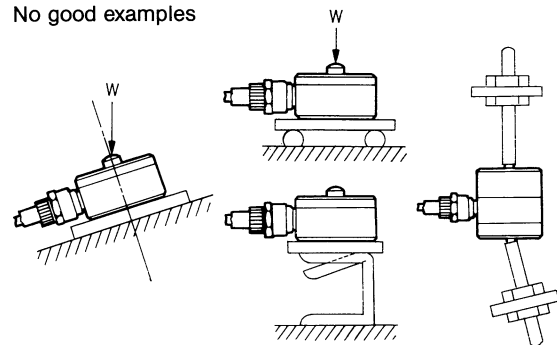

- Load cell is capable of compensating daily temperature changes. However, if it is partially heated, the accuracy may adversely be affected transiently. If it is not avoidable to use at temperatures beyond the operating temperature range, protect the load cell with a heat insulating material to keep it in the operating temperature range.
- If there is impact or vibration in the loading direction, it is difficult to determine the a case, select a load cell of which the rated capacity is sufficient enough. When the magnitude of acceleration is known, "mass multiplied by acceleration" should be considered in addition to the static load affected on the load cell, in order to determine the proper rated load capacity. This will also apply to the load cell exposed to horizontal impacts or vibrations.
- Do not disassemble the load cell.
- Avoid shocks or matters falling onto the load cell.
- Calibrate the load cell once a year or so. (Request the manufacturer to calibrate.) Whenever the load cell was subjected to an excessive horizontal force component or load, it must be calibrated.
- If an abnormal output value or other appears when the load cell is operated in a system, immediately interrupt operation of the system.

- Do not carry the load cell by holding its cable, and do not pull the cable forcibly to avoid the cable coming off.
- In vibration environment, fix the cable at its outlet and required portions.
Make sure that the bending radius of cable is longer than 6 times of a diameter of the cable.

5. Mounting

5.1 Measurement of a compression load (with LC-A, LC-E, LC-F, LCF-A, LCK-A, LC-FH, LC-FL, LC-J, LU-A, LU-E, LC-G, LC-V, LCV-A)

5.1.1 The figure below presents a typical mounting example intended for high accuracy of measurement.

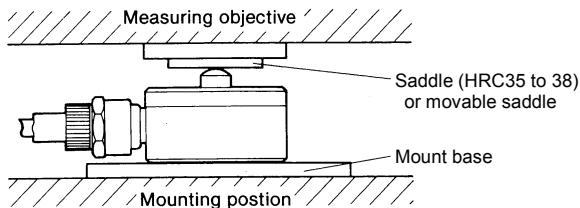

5.1.2 Before mounting a saddle to the load cell, weld or fix by using screws a steel plate to the load point of a measurement object. Provide this steel plate with screws in advance, and using them, mount a saddle.
For a saddle, use steel of hardness of HRC35 to 38 and apply grease to prevent rust.

5.1.3 Using the screws provided on the bottom of the load cell, fix the load cell to the mount base.

5.1.4 So mount the saddle and mount base that their surfaces are parallel to the load plane to ensure a vertical load to the load cell.

5.2 Measurement of a tension load (with LT-F, LTF-A, LT-FH, LT-FL, LU-A, LU-E, LT-G or LTZ-A)

TU (rod end) or RJ (rotation device) cannot be used with a high or low temperature load cell.

5.2.1 Mount the load cell using the screws provided in the center of the top and bottom of the load cell. The screws other than those in the center are provided for measuring a compression load. Therefore, be sure to use the only screws in the center.

Avoid bending or angular moment on the load cell, or they not only adversely affect measuring accuracy but also remarkably shorten the service life of the load cell.

5.2.2 As a safety measure, give an ample margin to the rated load capacity of the load cell.

Also as an emergency measure, provide a safety device to prevent the load cell installation from falling.

5.2.3 If the load cell is combined with special accessories (TR, TH, TU, RJ, etc.) by fully utilizing the load cell's rated load capacity, or where an overload is possible, the load cell installation should provide enough strength to meet the situation. In either case, contact the manufacturer in advance for information about a proper solution.

5.2.4 Be sure to properly lock every connection of the load cell with accessories as instructed below.

1) Apply a setscrew to every connection of the LU-E or LT-G with accessories.

For every setscrew in use, bore a countersunk hole on the mating object.

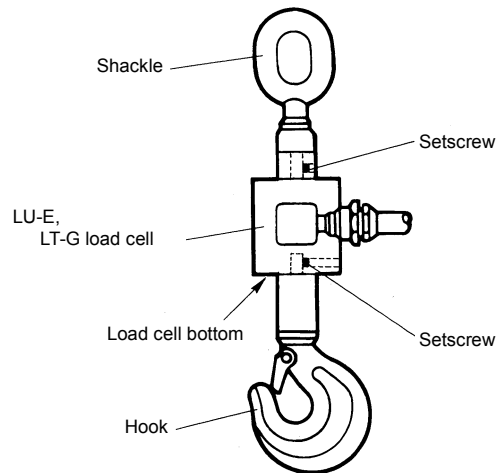

2) Apply a cotter pin (standard accessory) to every connection of the LT-F or LTF-A with accessories.
When doing, carefully avoid an edge of the accessory contacting the load cell, or the diaphragm of the load cell may be damaged.

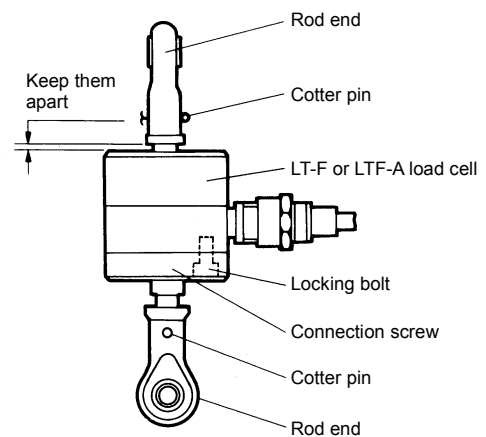

3) Use a double nut to connect LTZ-A with an accessory.
If there is possibility of loosening of the nut, use a cotter pin (standard accessory).
For a cotter pin, provide a groove on the mating object (3mm in width and 3mm in depth).

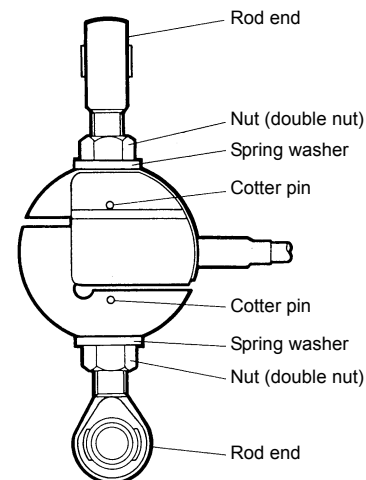

5.2.5 Before connecting RJ-B (rotation device) to LT-F or LTF-A remove the connection screws from the load cell. For connection, use suitable tightening torque described in the table below.

Rated load	0.5~2kN	5~20kN	50kN	100kN	200kN
Locking bolt	M6	M8	M10	M16	M20
Tightening torque	10N·m	30N·m	70N·m	270N·m	560N·m

5.2.6 When mounting the rod end to the load cell using screws, avoid an excessive torque, or damage may occur to the load cell especially if it is one with a low rated load capacity.

5.2.7 When mounting a load cell whose rated load capacity is below 2kN, also fix the cable, or the dead load of the cable may make a reading to flutter.

5.2.8 To measure tension with LU-A use it with the setscrew section facing downward to avoid the effect of a dead load. Excessively large tightening torque given to the setscrew may damage the load cell. Tightening torque should be below 0.1N·m. Also, fix the connection screw with a setscrew.

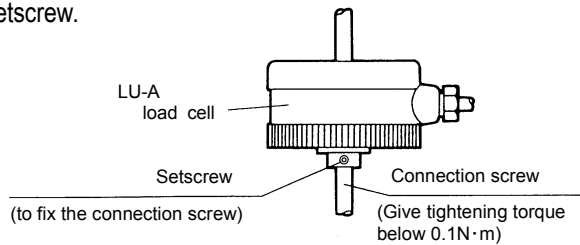

5.2.9 TU (rod end) or RJ (rotation device) cannot be used with a high or low temperature load cell. In stead, use TR (shackle) or TH (hook) or connection screws.

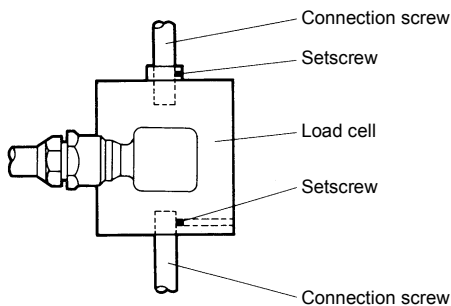

5.3 Simultaneous measurement of tension and compression (with LU-A, LU-E)

5.3.1 Mount the load cell using the screws provided on the top and bottom of the load cell.

5.3.2 The load cell is intended for measurement of a pure compression load as well as a pure tension load. Use the connection screws to mount the load cell. When set up, the connection screws should provide concentricity and parallelism. Any looseness of the connection screws disables accurate measurement.

5.3.3 RJ (rotation device) cannot be used for measurement of a compression load.

5.3.4 If alternating loads or shock loads affect the load cell, the fatigue strength of the load cell itself will raise a problem. If the load cell is intended to measure either one of the said loads, ask the manufacturer for a proper solution.

5.3.5 For other instructions, see the preceding item (5.2 Measurement of a tension load).

6. Connection

6.1 Wiring of the cable and the connector plug of the load cell is shown below.

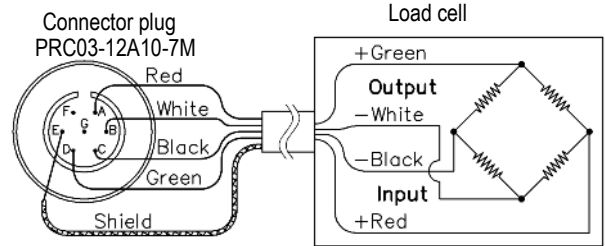

6.2 Perform connection as illustrated below when using a bridge box (a KYOWA product).

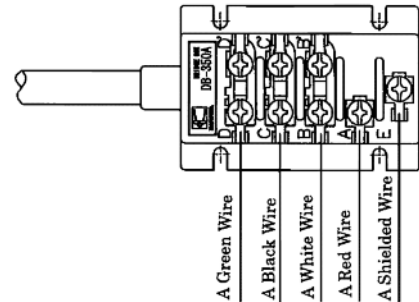

(Note) Measuring Method of Data Logger setting CH mode (ex. UCAM-60B and UCAM-500) is "4-gage method (Strain gage transducer)". Select the CH mode from "4-Gage (Constant voltage)".

6.3 The shield wire is connected to the mainframe on some types of load cells, and it is disconnected on other types of load cells. When grounding the shield wire from the load cell which is connected to an indicator, avoid a loop of the shield wire, or induction noise may occur, resulting in inaccuracy of measurement.

○ Load cell types on which the shield wire is connected.

LC-A, LC-E, LC-J

LU-A, LU-E

○ Load cell types on which the shield wire is disconnected.

LC-F, LCF-A, LC-FH, LC-FL, LC-G, LC-V, LCV-A,

LCK-A, LT-F, LTF-A, LT-FH, LT-FL, LT-G, LTZ-A

If it is desired to ground the shield wire, do it at the side of an amplifier/indicator. When induction or noise etc. occurs, connect an oscilloscope to the output terminal of an amplifier/indicator, and while viewing a waveform, perform suitable grounding. Note that grounding does not necessarily produce a better result.

6.4 When using several units of load cells at a time, use a junction box, which enables measurement of an average value or a sum value (through providing each load cell with a stabilized DC power supply) or a difference value. Select one that meets your measuring requirement.

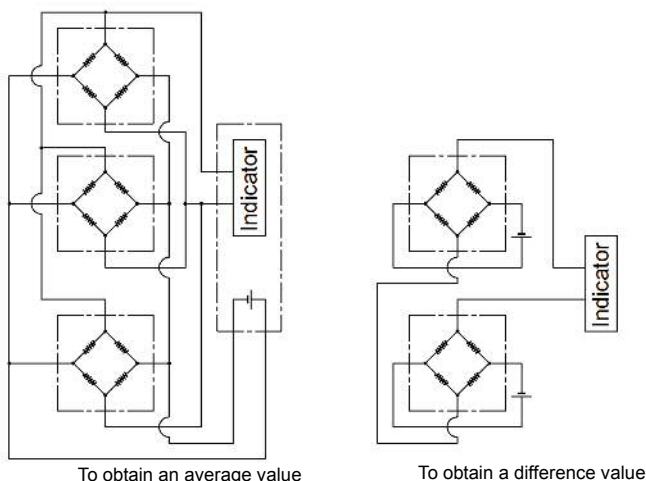
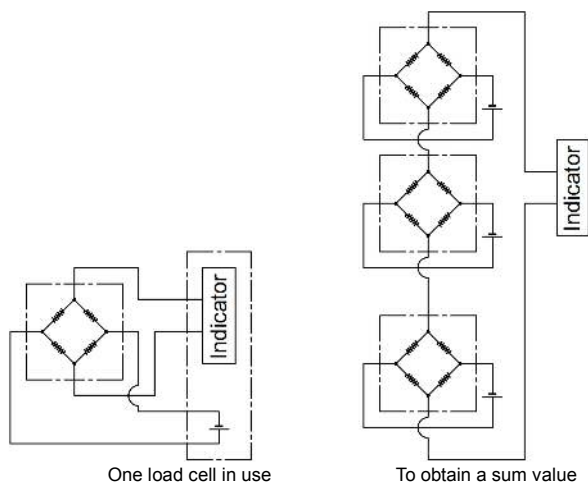

- 6.5 In order to make the most of the load cells' high performance capabilities, it is necessary to give a same length to all cables laid between the load cells and a junction box, and also to subject all the load cells and cables to a same ambient temperature.
- 6.6 In case the load cells's bridges are excited independently, supply them with highly stable power voltages.

7. Conversion

- 7.1 Use the calibration constant described in the test data sheet to convert a reading into a load value.
- 7.2 When a strain amplifier is in use, output reads in μ m/m equivalent strain ($\times 10^{-6}$ equivalent strain). Find a load value corresponding to μ m/m. Then, obtain a load value through multiplication using the following equation.

$$\text{Load value(N)} = \text{Strain amplifier's output } (\mu \text{ m/m}) \times \text{Calibration constant (N/1 } \mu \text{ m/m)}$$

- 7.3 When using an amplifier of other type or a recorder, first find the exact bridge exciting voltage applied. Second, find the load value that corresponds to 1μ V output voltage against 1V bridge excitation voltage. Then, obtain the load value through multiplication using the following equation.

$$\text{Load value(N)} = \frac{\text{Bridge output voltage } (\mu \text{ V})}{\text{Bridge excitation voltage (V)}} \times \text{Calibration constant (N/1 } \mu \text{ V/V)}$$

Sensitivity Decrease due to Cable Extension

If a strain gage transducer is connected to a signal conditioner, digital indicator or strain amplifier via extension cable, we cannot ignore the sensitivity decrease due to the extension cable resistance which lowers the voltage applied to the transducer.

The rated output with lowered sensitivity can be obtained through the following equation:

$$\text{True value } \varepsilon_0 = \left(\frac{R}{R+(r \times L)} \right) \varepsilon_i$$

Where, R : Transducer's input resistance (Ω)

r : Extension cable's reciprocating resistance (Ω) per meter

L : Extension cable length (m)

ε_i : Rated output written in the Test data sheet

8. Maintenance and inspection

- 8.1 Avoid water and oil on the end of the cable.
- 8.2 If the initial value or reading is found abnormal, measure input resistance, output resistance and insulation resistance (which should be $100\text{M}\Omega$ or higher). If the measured values are different from the descriptions of the inspection sheet, the cause may be a trouble. In this case, contact your nearest KYOWA representative for necessary inspection.

Caution

- For measurement of insulation resistance, apply a voltage lower than 50V to the insulation resistance tester.