

FEATURES

- **Stainless steel** IP67 single point load cell
- Suitable for the pricing scales, bench scales, belt scales etc
- Maximum platform size: 400*400mm

AVAILABLE MODELS

xxkg	C3	H6E-C3-xxkg-2B
xxkg	C3	H6E-C3-xxkg-2B-S1
xxkg	C3	H6E-C3-xxkg-2G
xxkg	C3	H6E-C3-xxkg-2G-S1

G: 브리지 회로와 차폐된 와이어 사이의 절연 저항은 0입니다.



SPECIFICATION

Maximum capacity (E _{max})	kg	20/30/50/75/100/150/200/250/300		
Accuracy class		C3		
Maximum number of load cell intervals (nLC)		3000		
Ratio of minimum LC verification interval Y=E _{max} / V _{min}		10000		
Combined error	%FS	±0.020		
Creep	%FS/30min	±0.016		
Temperature effect on sensitivity	%FS/10°C	±0.011		
Temperature effect on zero	%FS/10°C	±0.015		
Output sensitivity (=FS)	mV/V	2.0±0.2		
Input resistance	Ω	400±20		
Output resistance	Ω	351±2.0		
Insulation resistance	MΩ	≥ 5000 (50VDC)		
Zero balance	%FS	≤ ±1.5		
Compensated temperature	°C	-10~+40		
Operating temperature	°C	-35~+65		
Excitation, recommended voltage	V	5~12 (DC)		
Excitation maximum	V	18 (DC)		
Safe overload	%FS	150		
Ultimate overload	%FS	300		
Corner correction		0.02%load value/100mm		
ATEX class (optional)		II1G Ex ia IIC T4	II1D Ex iaD20 T73°C	II3G Ex nL IIC T4

참고: "S1" 출력 감도는 2.0±0.002mV/V이고 입력 저항은 384±4입니다.

DIMENSIONS IN MM

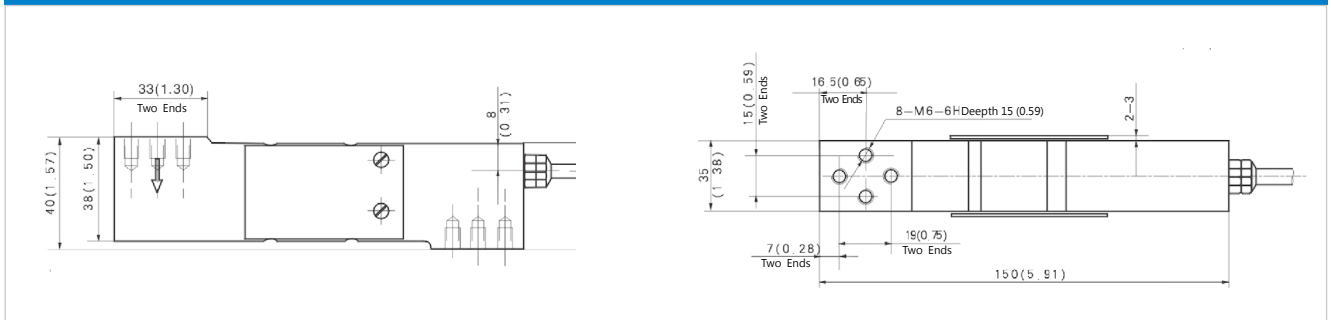

WIRING

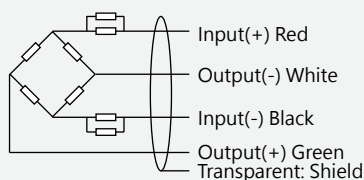

- Adopt shielded, 4 conductor cable: Φ5mm
- Standard cable length: 2m